



Selpro LLC. Greensboro, NC



Randolph

Style: Randolph
Wood Species: Walnut
Stain: Cherry
Overlay: Partial
(RWCP)

Materials and Construction:

Doors: Mortise and Tenon. Randolph is a 1/2" Overlay Raised Panel Door with 2" stiles and rails, solid walnut.

Drawers: 5/8" thick solid hard wood. Dovetailed joints, stained to match the Drawer front.
Bottoms are 1/2" walnut veneered plywood.
Glides are epoxy coated under mount, 3/4" extensions.
Drawer fronts are 5 piece construction 1/2" overlay

Case: Face frames are built with select Walnut and have Mortise and Tenon joints. Face frames are solid 3/4" thick with 1 1/2" stiles and rails.
Sides are Walnut veneered 7/16" plywood. The interior and sides are stained to match the door.
Shelves are 5/8" thick Walnut veneered plywood stained to match the door, adjustable and front edge banded.
Backs are framed with a 1/2" plywood hang rail.

Hinges: Six way adjustable.

Reveals: Wall cabinets have a 1" reveal all the way around. This allows the cabinet to be flipped and Molding applied.
Base cabinets have a 1" reveal all the way around. Drawers have a 1" reveal on the sides and bottom and a 1 1/4" reveal on the top.

Finish: Cherry



Chatham

Style: Chatham
Wood Species: Oak
Stain: Natural
Overlay: Partial
(CONP)

Materials and Construction:

Doors: Mortise and Tenon. Chatham is a 1/2" overlay flat panel Shaker door with 2" Stiles and rails, solid Oak.

Drawers: 5/8" thick solid hardwood. Dowel pin construction, stained to match the drawer front.

Bottoms are 1/2" oak veneered plywood.

Glides are epoxy coated under mount 3/4" extensions.

Drawer fronts are 5 piece Shaker construction 1/2" overlay. Stiles are 2" rails are 1 1/2"

Case: Face frames are built with select Oak and have Mortise and Tenon joints.

Face Frames are solid 3/4" thick with 1 1/2" stiles and rails.

Sides are Oak veneered 7/16" plywood. The interior and sides are stained to match the door.

Shelves are 5/8" thick Oak veneered plywood stained to match the door, adjustable and front edge banded.

Backs are framed with a 1/2" plywood hang rail.

Hinges: Six way adjustable.

Reveals: Wall cabinets have a 1" reveal all the way around. This allows the cabinet to be flipped and molding applied.

Base cabinets have a 1" reveal all the way around. Drawers have a 1" reveal On the sides and bottom and a 1 1/4" reveal on the top.

Finish: Natural

Hatteras

Style: Hatteras
Wood Species: Birch
Finish: Painted
Color: Canvas with a Cocoa Glaze
Overlay: Full
(NBW-0712)

Materials and Construction:

Doors:

Mitered full overlay door with a raised MDF door panel

Drawers:

Drawer Front - mitered 5 piece, flat panel, full overlay
Drawer Sides – $\frac{3}{4}$ inch solid wood sides, dovetail joints, finished natural
Drawer Bottoms – $\frac{1}{2}$ inch birch veneered plywood
Glides – undermount, full extension, soft close

Case:

Face Frames – solid wood mortise and tennon construction
 $\frac{3}{4}$ " thick with $1\frac{1}{2}$ " stiles and rails.
Case Sides – $\frac{1}{2}$ inch birch veneered plywood, natural finish inside and out
Shelves – $\frac{3}{4}$ inch front and back edge banded, adjustable
Base cabinet shelves are $\frac{3}{4}$ cabinet depth
Backs – $\frac{1}{8}$ inch plywood framed in $\frac{1}{2}$ inch plywood and dadoed into the sides
Wall cabinets come with a 1 inch hang rail top and bottom
Base Cabinets - 2 piece I-beam construction instead of corner blocks
for added strength

Hinges:

Concealed Euro style hinges

Reveals:

Wall cabinets have a 1 inch reveal at the top and $\frac{3}{8}$ inch reveal at the bottom
Base cabinets have a 1 inch reveal at the top

Finish: Painted in Canvas with a Cocoa Glaze

Hatteras Cabinets



Randolph Cabinets



Chatham Cabinets





Vintage Onyx

| | |
|-----------------|-------------------------------|
| Style: | Vintage Onyx |
| Species: | Birch |
| Finish: | Painted |
| Color: | Black with Sand-Through Edges |
| Overlay: | Full |

Materials and Construction:

Doors:

Mitered full overlay door with a raised door panel

Drawers:

Drawer Front - mitred 5 piece, flat panel, full overlay

Drawer Sides - $\frac{3}{4}$ inch solid wood sides, dovetail joints, finished natural

Drawer Bottoms - $\frac{1}{2}$ inch birch veneered plywood

Glides - undermount, full extension, soft close

Case:

- Face Frames - solid wood mortise and tenon construction, $\frac{3}{4}$ inch thick with $1\frac{1}{2}$ inch stiles and rails
- Case Sides - $\frac{1}{2}$ inch birch veneered plywood, natural finish inside and out, wall cabinets come with black finished interior
- Shelves - $\frac{3}{4}$ inch front and back edge banded, adjustable base cabinet shelves are $\frac{3}{4}$ cabinet depth
- Backs - $\frac{1}{8}$ inch plywood framed in $\frac{1}{2}$ inch plywood and dadoed into the sides, wall cabinets come with a 1 inch hang rail top and bottom
- Base Cabinets - 2 piece I-beam construction instead of corner blocks for added strength

Hinges:

Concealed Euro style hinges

Reveals:

Wall cabinets have a 1 inch reveal at the top and $\frac{3}{8}$ inch reveal at the bottom

Base cabinets have a 1 inch reveal at the top

Finish:

Black with Sand-Through Edges

Vintage Onyx



Randolph

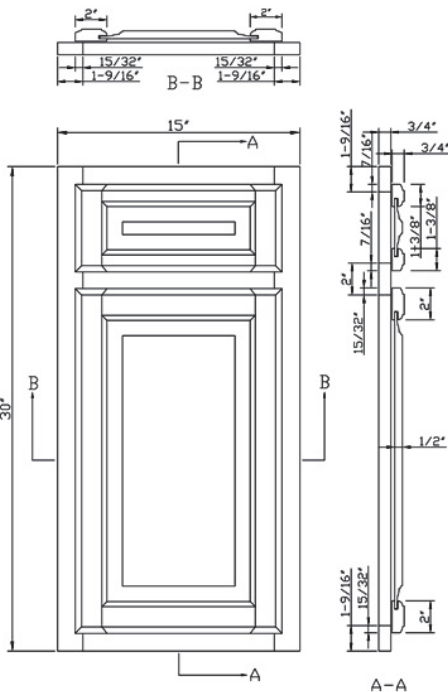

Chatham

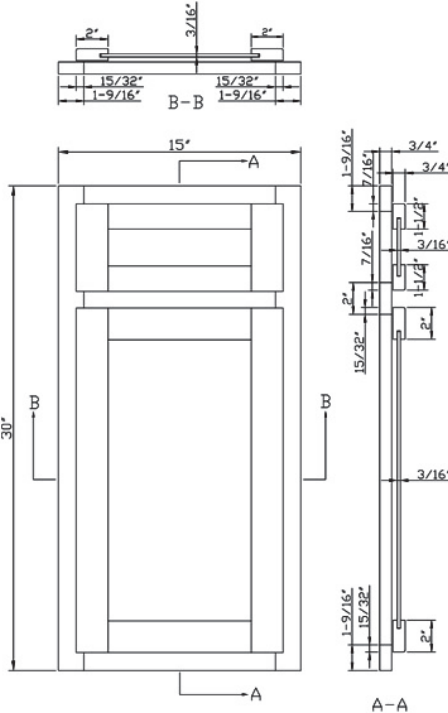

WALL CABINETS (12" Deep)

WALL

WALL CABINET
12" HIGH
BUTT DOORS

Available in Randolph, Chatham, Hatteras

W3012
W3312
W3612
W3912

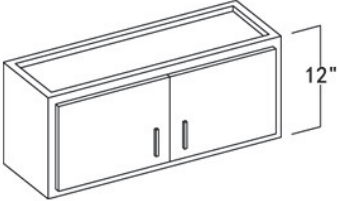

No shelf
No center mullion

2 DOORS

WALL CABINET
12" HIGH
(24" DEEP)
BUTT DOORS

Available in Randolph, Chatham, Hatteras

W361224
W391224

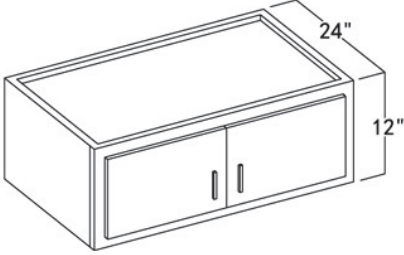

CAUTION INSTALLER: 24" deep wall cabinets require additional support. They should be screwed on both sides to adjacent cabinet, wall, soffit or ceiling joist.

No shelf
No center mullion

2 DOORS

WALL CABINET
15" HIGH
BUTT DOORS

Available in Randolph, Chatham, Hatteras

W3015
W3315
W3615
W3915

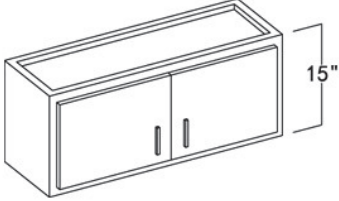

No shelf
No center mullion

2 DOORS

WALL CABINET
15" HIGH
(24" DEEP)
BUTT DOORS

Available in Randolph, Chatham, Hatteras

W361524
W391524

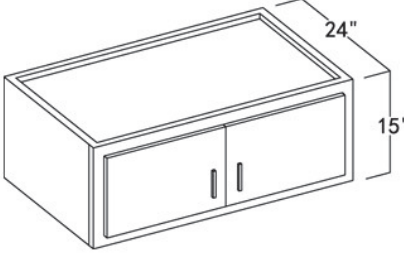

CAUTION INSTALLER: 24" deep wall cabinets require additional support. They should be screwed on both sides to adjacent cabinet, wall, soffit or ceiling joist.

No shelf
No center mullion

2 DOORS

WALL CABINET
18" HIGH
BUTT DOORS

Available in Randolph, Chatham, Hatteras

W3018
W3318
W3618
W3918

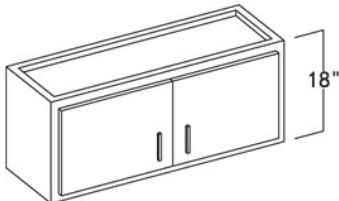

No shelf
No center mullion

2 DOORS

WALL CABINET
18" HIGH
(24" DEEP)
BUTT DOORS

Available in Randolph, Chatham, Hatteras

W361824
W391824

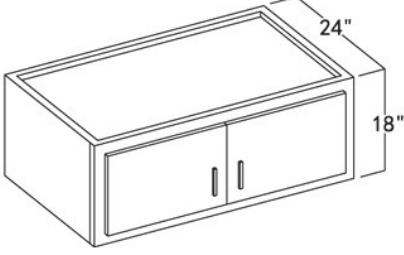

CAUTION INSTALLER: 24" deep wall cabinets require additional support. They should be screwed on both sides to adjacent cabinet, wall, soffit or ceiling joist.

No shelf
No center mullion

2 DOORS

WALL CABINETS (12" Deep)

WALL

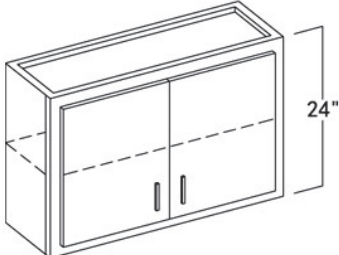
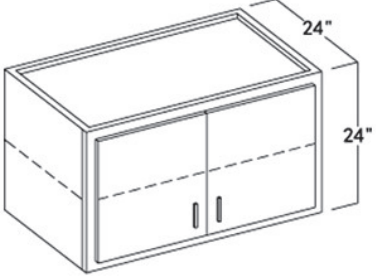
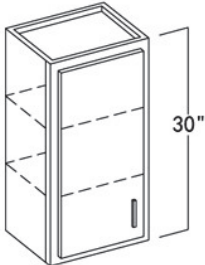
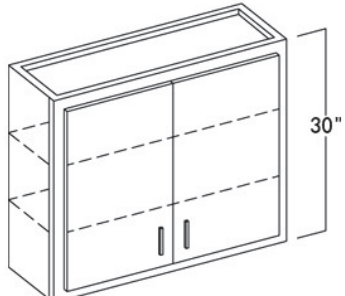
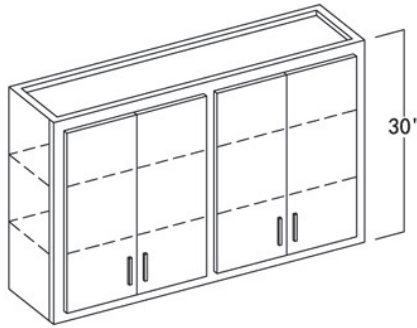
| | |
|--|--|
| <p>WALL CABINET 24" HIGH BUTT DOORS</p> <p>Available in Randolph, Hatteras</p> <p>W3024 W3324 W3624 W3924</p>  <p>1 Adjustable shelf No center mullion</p> <p><i>2 DOORS</i></p> | <p>WALL CABINET 24" HIGH (24" DEEP) BUTT DOORS</p> <p>Available in Randolph, Hatteras</p> <p>W362424 W392424</p>  <p>CAUTION INSTALLER: 24" deep wall cabinets require additional support. They should be screwed on both sides to adjacent cabinet, wall, soffit or ceiling joist.</p> <p>1 Adjustable shelf No center mullion</p> <p><i>2 DOORS</i></p> |
| <p>WALL CABINET 30" HIGH SINGLE DOOR</p> <p>Available in Randolph, Chatham, Hatteras</p> <p>W930 W1230 W1530 W1830 W2130</p>  <p>2 Adjustable shelves</p> <p><i>1 DOOR</i></p> | <p>WALL CABINET 30" HIGH BUTT DOORS</p> <p>Available in Randolph, Chatham, Hatteras</p> <p>W2430 W2730 W3030 W3330 W3630 W3930 W4230</p>  <p>2 Adjustable shelves No center mullion</p> <p><i>2 DOORS</i></p> |
| <p>WALL CABINET 30" HIGH BUTT DOORS</p> <p>Available in Randolph, Chatham, Hatteras</p> <p>W4830</p>  <p>2 Adjustable shelves One center mullion</p> <p><i>4 DOORS</i></p> | |

WALL CABINETS (12" Deep)

WALL

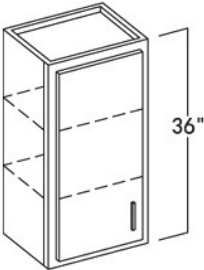
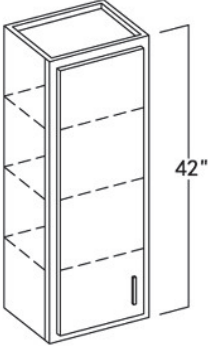
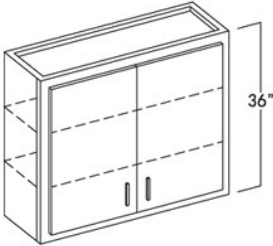
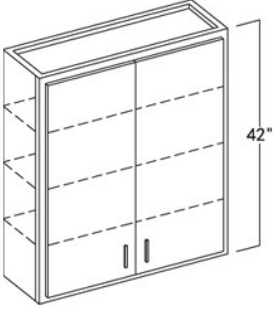
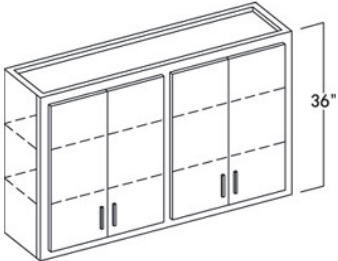
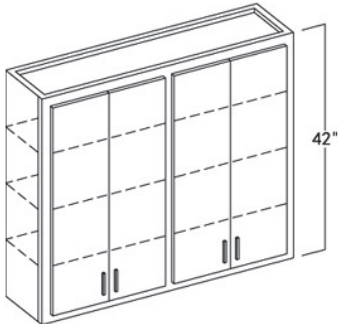
| | |
|--|---|
| <p>WALL CABINET 36" HIGH SINGLE DOOR</p> <p>Available in Randolph, Chatham, Hatteras</p> <p>W936 W1236 W1536 W1836 W2136</p>  <p>2 Adjustable shelves</p> <p><i>1 DOOR</i></p> | <p>WALL CABINET 42" HIGH SINGLE DOOR</p> <p>Available in Randolph, Hatteras</p> <p>W942 W1242 W1542 W1842 W2142</p>  <p>3 Adjustable shelves</p> <p><i>1 DOOR</i></p> |
| <p>WALL CABINET 36" HIGH BUTT DOORS</p> <p>Available in Randolph, Chatham, Hatteras</p> <p>W2436 W2736 W3036 W3336 W3636 W3936 W4236</p>  <p>2 Adjustable shelf No center mullion</p> <p><i>2 DOORS</i></p> | <p>WALL CABINET 42" HIGH BUTT DOORS</p> <p>Available in Randolph, Hatteras</p> <p>W2442 W2742 W3042 W3342 W3642 W3942 W4242</p>  <p>3 Adjustable shelves No center mullion</p> <p><i>2 DOORS</i></p> |
| <p>WALL CABINET 36" HIGH BUTT DOORS</p> <p>Available in Randolph, Chatham, Hatteras</p> <p>W4836</p>  <p>2 Adjustable shelves One center mullion</p> <p><i>4 DOORS</i></p> | <p>WALL CABINET 42" HIGH BUTT DOORS</p> <p>Available in Randolph, Hatteras</p> <p>W4842</p>  <p>3 Adjustable shelves One center mullion</p> <p><i>4 DOORS</i></p> |

WALL CABINETS (12" Deep)

WALL

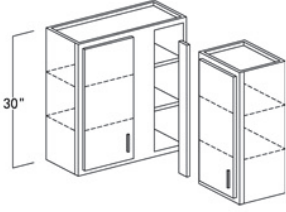
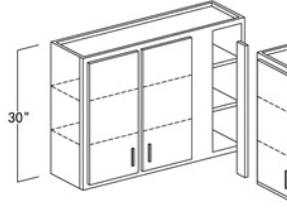
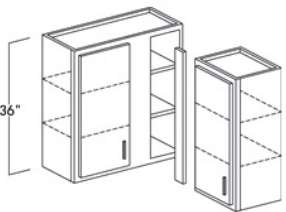
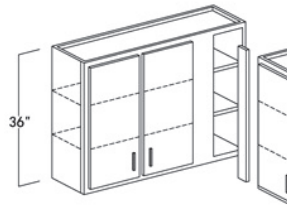
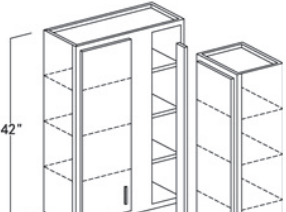
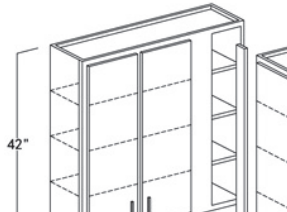

| | |
|---|---|
| <p>WALL BLIND CABINET Available in Randolph, Chatham, Hatteras 30" HIGH SINGLE DOOR</p> <p>WBC2730 WBC3030 WBC3330</p>  <p>Wall Blind Cabinet is reversible 2 adjustable shelves Filler sold separately</p> <p style="text-align: right;">1 DOOR</p> | <p>WALL BLIND CABINET Available in Randolph, Chatham, Hatteras 30" HIGH BUTT DOORS</p> <p>WBC3630 WBC3930 WBC4230</p>  <p>Wall Blind Cabinet is reversible 2 adjustable shelves Filler sold separately</p> <p style="text-align: right;">2 DOORS</p> |
| <p>WALL BLIND CABINET Available in Randolph, Chatham, Hatteras 36" HIGH SINGLE DOOR</p> <p>WBC2736 WBC3036 WBC3336</p>  <p>Wall Blind Cabinet is reversible 2 adjustable shelves Filler sold separately</p> <p style="text-align: right;">1 DOOR</p> | <p>WALL BLIND CABINET Available in Randolph, Chatham, Hatteras 36" HIGH BUTT DOORS</p> <p>WBC3636 WBC3936 WBC4236</p>  <p>Wall Blind Cabinet is reversible 2 adjustable shelves Filler sold separately</p> <p style="text-align: right;">2 DOORS</p> |
| <p>WALL BLIND CABINET Available in Randolph, Hatteras 42" HIGH SINGLE DOOR</p> <p>WBC2742 WBC3042 WBC3342</p>  <p>Wall Blind Cabinet is reversible 3 adjustable shelves Filler sold separately</p> <p style="text-align: right;">1 DOOR</p> | <p>WALL BLIND CABINET Available in Randolph, Hatteras 42" HIGH BUTT DOORS</p> <p>WBC3642 WBC3942 WBC4242</p>  <p>Wall Blind Cabinet is reversible 3 adjustable shelves Filler sold separately</p> <p style="text-align: right;">2 DOORS</p> |

**INSTALLATION EXAMPLE
WALL BLIND CORNER CABINET**

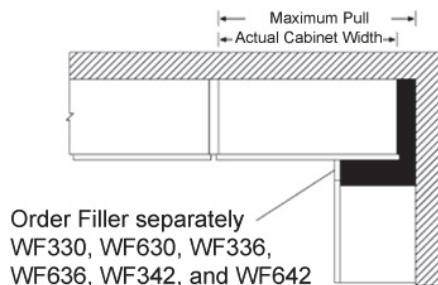
| Item Name | Actual Width | Maximum Pull |
|-----------|--------------|--------------|
| WBC27 | 27" | 30" |
| WBC30 | 30" | 33" |
| WBC33 | 33" | 36" |
| WBC36 | 36" | 39" |
| WBC39 | 39" | 42" |
| WBC42 | 42" | 45" |

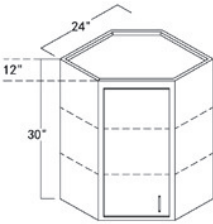
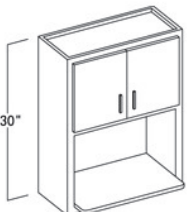
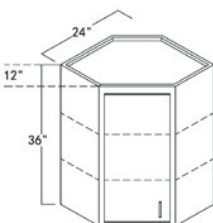

WALL CABINETS (12" Deep)

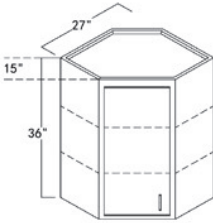
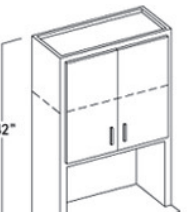
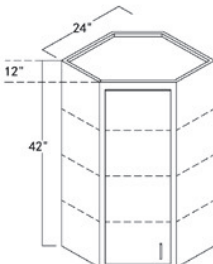
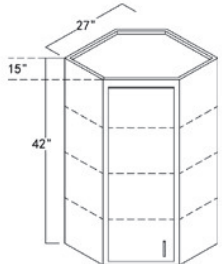

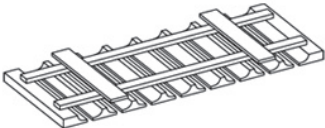
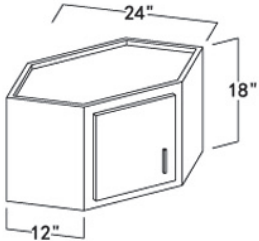
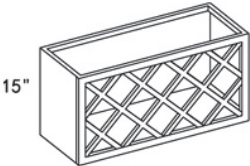
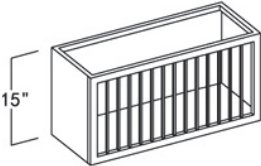
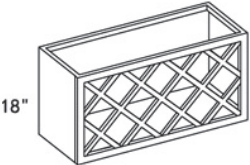
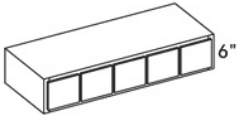
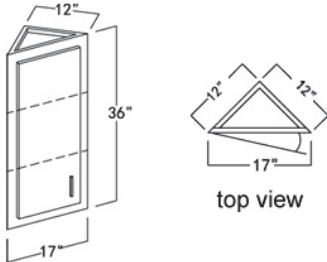
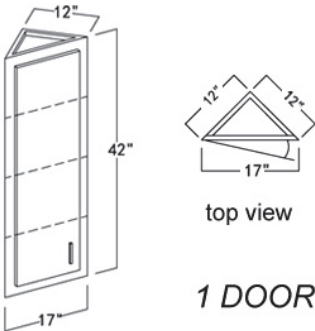

| | |
|--|--|
| <p>WALL DIAGONAL CORNER CABINET 30" HIGH SINGLE DOOR</p> <p>WDC2430</p>  <p>Available in Randolph, Chatham, Hatteras</p> <p>2 adjustable shelves</p> <p>1 DOOR</p> | <p>WALL MICROWAVE CABINET 30" HIGH BUTT DOORS</p> <p>WM2730</p> <p>Opening 23 7/8" X 16 1/4"</p>  <p>Available in Randolph, Chatham, Hatteras</p> <p>With the shelf Microwave opening is 15 9/16" No shelf</p> <p>2 DOORS</p> |
| <p>WALL DIAGONAL CORNER CABINET 36" HIGH SINGLE DOOR</p> <p>WDC2436</p>  <p>Available in Randolph, Chatham, Hatteras</p> <p>2 adjustable shelves</p> <p>1 DOOR</p> | <p>WALL MICROWAVE CABINET 36" HIGH BUTT DOORS</p> <p>WM2736</p> <p>Opening 23 7/8" X 16 1/4"</p>  <p>Available in Randolph, Chatham, Hatteras</p> <p>With the shelf Microwave opening is 15 9/16" No shelf</p> <p>2 DOORS</p> |
| <p>WALL DIAGONAL CORNER CABINET 36" HIGH SINGLE DOOR</p> <p>WDC273615</p>  <p>Available in Randolph, Hatteras</p> <p>2 adjustable shelves</p> <p>1 DOOR</p> | <p>WALL MICROWAVE CABINET 42" HIGH BUTT DOORS</p> <p>WM2742</p> <p>Opening 23 7/8" X 16 1/4"</p>  <p>Available in Randolph, Chatham, Hatteras</p> <p>With the shelf Microwave opening is 15 9/16" One shelf</p> <p>2 DOORS</p> |
| <p>WALL DIAGONAL CORNER CABINET 42" HIGH SINGLE DOOR</p> <p>WDC2442</p>  <p>Available in Randolph, Hatteras</p> <p>3 adjustable shelves</p> <p>1 DOOR</p> | <p>WALL DIAGONAL CORNER CABINET 42" HIGH SINGLE DOOR</p> <p>WDC274215</p>  <p>Available in Randolph, Hatteras</p> <p>3 adjustable shelves</p> <p>1 DOOR</p> |

WALL CABINETS (12" Deep)

| | |
|--|--|
| <p>GLASS RACK Available in Randolph, Hatteras</p> <p>WGR3007</p>  | <p>WALL CORNER APPLIANCE GARAGE Available in Randolph, Hatteras 18" HIGH SINGLE DOOR</p> <p>WDC2418</p>  <p>In Hatteras cabinet does not include hinges Fits under wall corner diagonal cabinets No shelf</p> <p>1 DOOR</p> |
| <p>WALL WINE RACKS Available in Randolph 15" HIGH</p> <p>WWR3015</p>  | <p>WALL PLATE RACK Available in Randolph 15" HIGH</p> <p>WPR3015</p>  |
| <p>WALL WINE RACKS Available in Randolph 18" HIGH</p> <p>WWR3018</p>  | <p>WALL SPICE DRAWER CABINET Available in Randolph 6" HIGH</p> <p>SDC30</p>  |
| <p>WALL DIAGONAL END CABINET Available in Randolph, Hatteras 36" HIGH SINGLE DOOR</p> <p>WCA1236</p>  <p>2 adjustable shelves</p> <p>1 DOOR</p> | <p>WALL DIAGONAL END CABINET Available in Randolph, Hatteras 42" HIGH SINGLE DOOR</p> <p>WCA1242</p>  <p>3 adjustable shelves</p> <p>1 DOOR</p> |

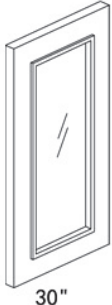
WALL CABINETS

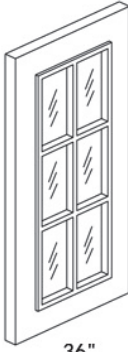
WALL

| | |
|--|--|
| <p>CHATHAM WALL GLASS DOOR 30" HIGH</p> <p>Available in Chatham</p> <p>WMD1530G WMD1830G WMDCW2430</p>  <p>30"</p> <p>Glass Doors in the Chatham are open frame (no mullions) Door only, glass included</p> | <p>CHATHAM WALL GLASS DOOR 36" HIGH</p> <p>Available in Chatham</p> <p>WMD1536G WMD1836G WMDCW2436</p>  <p>36"</p> <p>Glass Doors in the Chatham are open frame (no mullions) Door only, glass included</p> |
| <p>RANDOLPH WALL MULLION DOOR 30" HIGH</p> <p>Available in Randolph</p> <p>WMDCW2430</p>  <p>30"</p> <p>Glass Doors in Randolph have mullions Door Only, Glass Included All Cabinets 24"wide and up require two doors</p> | <p>RANDOLPH WALL MULLION DOOR 36" HIGH</p> <p>Available in Randolph</p> <p>WMD1536 WMD1836 WMD2136 WMD2436 WMD2736 WMD3036 WMD3636 WMDCW2436 WMDCW2736</p>  <p>36"</p> <p>Glass Doors in Randolph have mullions Door Only, Glass Included All Cabinets 24"wide and up require two doors</p> |
| <p>RANDOLPH WALL MULLION DOOR 42" HIGH</p> <p>Available in Randolph</p> <p>WMD1542G WMD1842G WMD2142G WMD2442G WMD2742G WMD3042G WMD3642G WMDCW2442 WMDCW2742</p>  <p>42"</p> <p>Glass Doors in Randolph have mullions Door Only, Glass Included All Cabinets 24"wide and up require two doors</p> | Empty cell |

BASE CABINETS (24" Deep, 34-1/2" High)

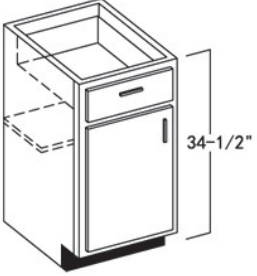
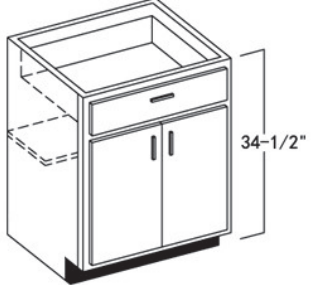
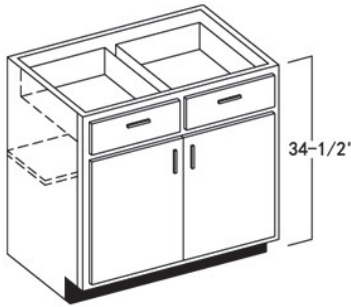
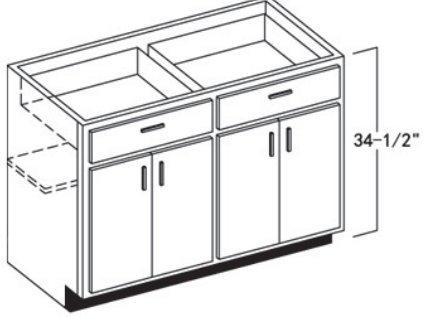
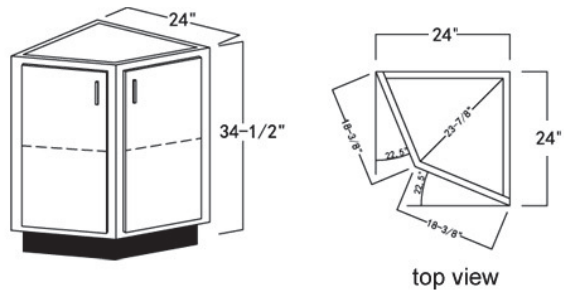
| | |
|---|---|
| <p>BASE CABINET SINGLE DOOR</p> <p>Available in Randolph, Chatham, Hatteras</p> <p>B9 B12 B15 B18 B21</p>  <p>1 Adjustable shelf</p> <p>1 DOOR 1 DRAWER</p> | <p>BASE CABINET BUTT DOORS</p> <p>Available in Randolph, Chatham, Hatteras</p> <p>B24 B27 B30</p>  <p>In Hatteras B27, and B30 come with 2 drawers. 1 Adjustable shelf No center mullion</p> <p>2 DOORS 1 DRAWER</p> |
| <p>BASE CABINET BUTT DOORS</p> <p>Available in Randolph, Chatham, Hatteras</p> <p>B33 B36 B39 B42</p>  <p>1 Adjustable shelf No center mullion</p> <p>2 DOORS 2 DRAWERS</p> | <p>BASE CABINET BUTT DOORS</p> <p>Available in Randolph, Chatham, Hatteras</p> <p>B48</p>  <p>1 Adjustable shelf One center mullion</p> <p>4 DOORS 2 DRAWERS</p> |
| <p>BASE END CABINET DOUBLE DOORS</p> <p>Available in Randolph, Hatteras</p> <p>BEC24</p>  <p>1 Adjustable shelf</p> <p>2 DOORS</p> | |

BASE

BASE CABINETS (24" Deep, 34-1/2" High)

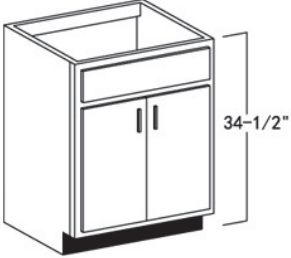
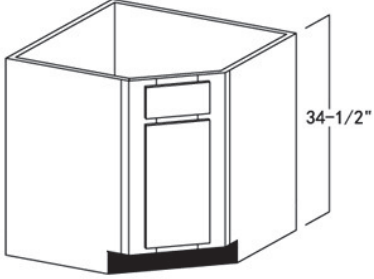
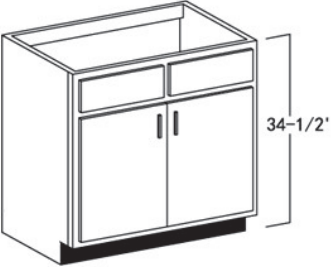
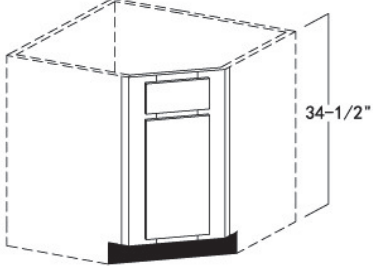
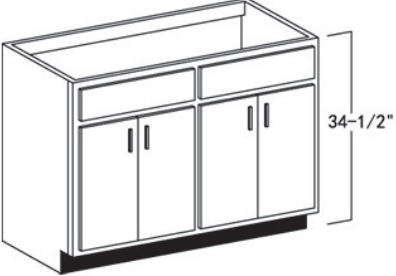
| | |
|---|---|
| <p>SINK / RANGE BASE CABINET BUTT DOORS</p> <p>Available in Randolph, Chatham, Hatteras</p> <p>SB24 SB27 SB30</p>  <p>No shelf</p> <p>2 DOORS 1 FALSE FRONT</p> | <p>CORNER SINK BASE SINGLE DOOR</p> <p>Available in Randolph, Chatham</p> <p>NCSB36</p>  <p>No shelf</p> <p>1 DOOR 1 FALSE FRONT</p> |
| <p>SINK / RANGE BASE CABINET BUTT DOORS</p> <p>Available in Randolph, Chatham, Hatteras</p> <p>SB33 SB36 SB39 SB42</p>  <p>No shelf</p> <p>2 DOORS 2 FALSE FRONTS</p> | <p>CORNER SINK FRONT SINGLE DOOR</p> <p>Available in Randolph, Chatham, Hatteras</p> <p>CSF36 CSF42</p>  <p>Front only No sides, floor, shelf, or toekick</p> <p>1 DOOR 1 FALSE FRONT</p> |
| <p>SINK / RANGE BASE CABINET BUTT DOORS</p> <p>Available in Randolph, Chatham, Hatteras</p> <p>SB48</p>  <p>No shelf</p> <p>4 DOORS 2 FALSE FRONTS</p> | |

BASE CABINETS (24" Deep, 34-1/2" High)

BLIND BASE CABINET

Available in Randolph, Chatham, Hatteras

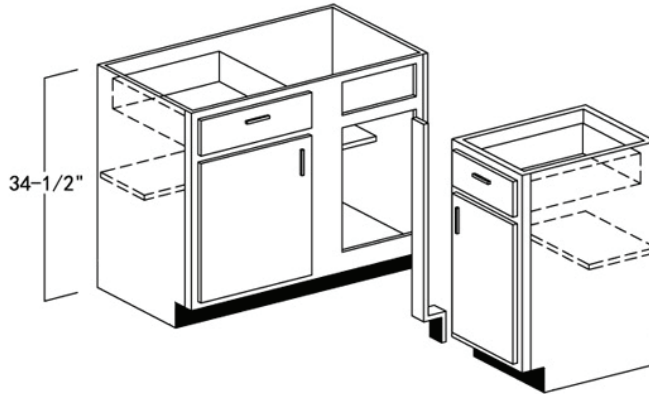

| | Actual Width (A) | Maximum Pull (B) |
|-------|------------------|------------------|
| BBC36 | 24" | 39" |
| BBC39 | 30" | 42" |
| BBC42 | 36" | 45" |
| BBC45 | 42" | 48" |
| BBC48 | 48" | 51" |

1 Adjustable shelf

Door can be reversed by moving hinge screw to pre-drilled holes on opposite side of front face frame.

*1 DOOR
1 DRAWER*

NOTE: Most hardware require that blind corner cabinets be pulled and fillers installed between adjacent cabinet for proper clearance and operation of doors and drawers.

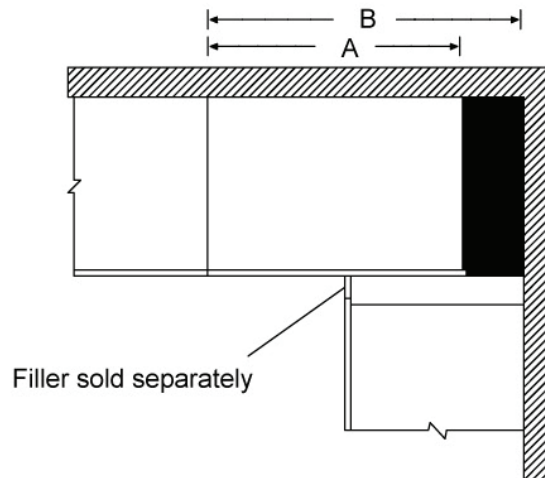

BASE

BASE CABINETS (24" Deep, 34-1/2" High)

BASE LAZY SUSAN CABINET

Available in Randolph, Chatham

LS3612

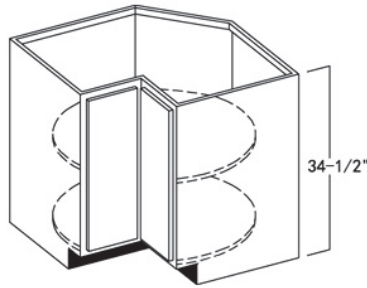

Equipped with 2 revolving shelves
Requires 36"x36" of wall space
Doors swing out and are not attached to shelves

BASE SPICE DRAWER CABINET

Available in Randolph, Hatteras

BSDC6



BASE SPICE PULL OUT CABINET SINGLE DOOR

Available in Randolph

SP09

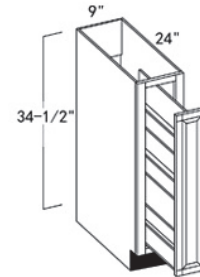

1 DOOR
3 RACKS

BASE CABINET DRAWER BASE WITH THREE DRAWERS

Available in Randolph, Chatham, Hatteras

- DB12
- DB15
- DB18
- DB21
- DB24
- DB27
- DB30
- DB36

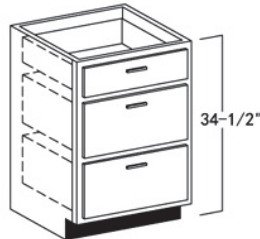

3 DRAWERS

BASE WINE RACK

Available in Randolph

BWR6

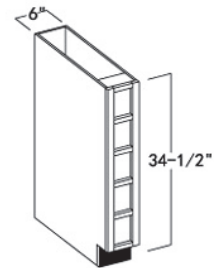

1 column with bottle compartments

BASE TRASH CAN CABINET

Available in Randolph, Chatham, Hatteras

BWBK18-2

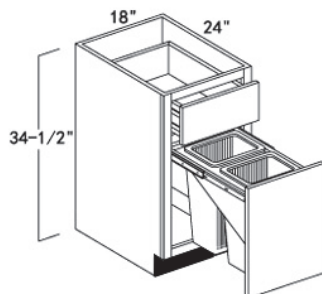

In Hatteras cabinet does not include trash can, must be ordered separately
Contains 2 small trashcans

BASE WINE RACK

Available in Randolph

BWR12

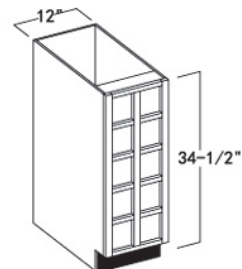

2 columns with bottle compartments

BASE

TALL CABINETS (84", 90" & 96" High)

OVEN CABINETS

84" HIGH
24" DEEP

OC3084
OC3384

Top hole is 23 3/4" wide x 14 7/8" high
Bottom hole is 23 3/4" wide x 18 3/8" high

Maximum width cutout is 27 1/2" for OC30 and 30 1/2" for OC33
Maximum cutout is 54" when leaving the drawer in.
Maximum cutout is 63 1/4" when drawer is taken out also.

Top Section is 15"

Cabinet can be modified in the field to accept most appliances

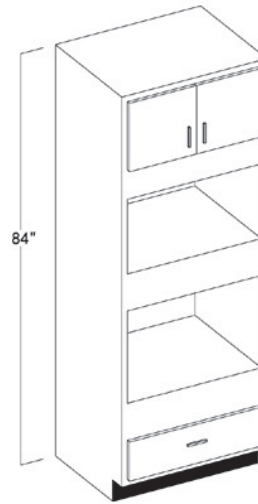

Available in
Randolph, Chatham

2 DOORS
1 DRAWER

OVEN CABINETS

90" HIGH
24" DEEP

OC3090
OC3390

Top hole is 23 3/4" wide x 14 7/8" high
Bottom hole is 23 3/4" wide x 18 3/8" high

Maximum width cutout is 27 1/2" for OC30 and 30 1/2" for OC33
Maximum Cutout is 54" when leaving the drawer in.
Maximum cutout is 63 1/4" when drawer is taken out also.

Top section is 21"

Cabinet can be modified in the field to accept most appliances

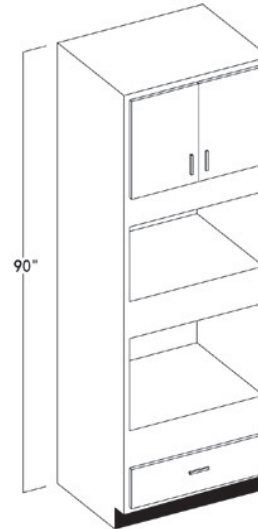

Available in
Randolph, Chatham

2 DOORS
1 DRAWER

OVEN CABINETS

96" HIGH
24" DEEP

OC3096
OC3396

Top hole is 23 3/4" wide x 14 7/8" high
Bottom hole is 23 3/4" wide x 18 3/8" high

Maximum width cutout is 27 1/2" for OC30 and 30 1/2" for OC33
Maximum cutout is 54" when leaving both drawers in.
Maximum cutout is 62" when leaving one drawer in.
Maximum cutout is 70" when taking both drawers out.

Top section is 19 1/2"

Cabinet can be modified in the field to accept most appliances.

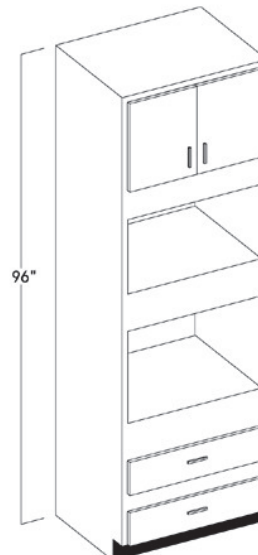



Available in
Randolph

2 DOORS
2 DRAWERS

TALL

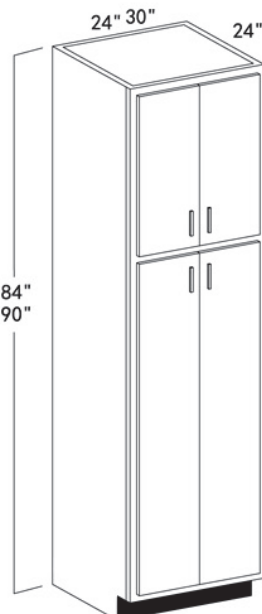
TALL CABINETS (84", 90" & 96" High)

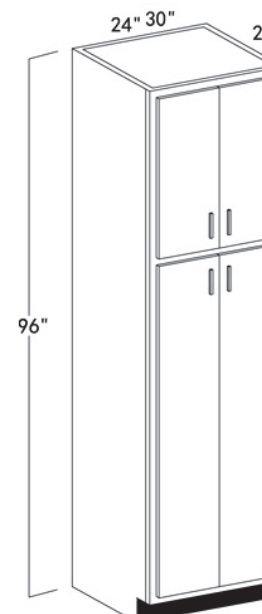
| | |
|---|--|
| <p>WALL PANTRIES 84" & 90" HIGH SINGLE DOOR</p> <p>Available in Randolph, Chatham</p> <p>WP1884 WP1890</p>  <p>4 adjustable shelves</p> <p>2 DOORS</p> | <p>WALL PANTRIES 84" & 90" HIGH BUTT DOORS</p> <p>Available in Randolph, Chatham</p> <p>WP2484 WP2490 WP3084 WP3090</p>  <p>No center mullion 4 adjustable shelves</p> <p>4 DOORS</p> |
| <p>WALL PANTRIES 96" HIGH SINGLE DOOR</p> <p>Available in Randolph</p> <p>WP1896</p>  <p>4 Adjustable shelves</p> <p>2 DOORS</p> | <p>WALL PANTRIES 96" HIGH BUTT DOORS</p> <p>Available in Randolph</p> <p>WP2496 WP3096</p>  <p>No center mullion 4 adjustable shelves</p> <p>4 DOORS</p> |

TALL

VANITY CABINETS (21" Deep)

VANITY SINK
30" and 34-1/2" HIGH
BUTT DOORS

Available in Randolph, Chatham, Hatteras

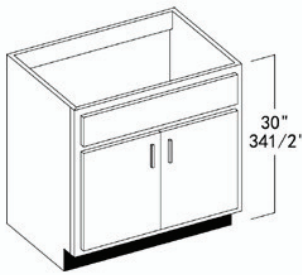
| | | |
|-----------------|---------------------|---|
| 30" HIGH | 34-1/2" HIGH |  |
| V2421 | V2421T | |
| V2721 | V2721T | |
| V3021 | V3021T | |
| V3621 | V3321T | |
| | V3621T | |
| | | |

V2721 is not available in Hatteras
No shelf

2 DOORS
1 FALSE FRONT

VANITY SINK WITH DRAWERS
30" and 34-1/2" HIGH
BUTT DOORS

Available in Randolph, Chatham, Hatteras

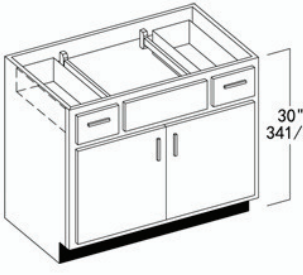
| | | |
|-----------------|---------------------|---|
| 30" HIGH | 34-1/2" HIGH |  |
| VB3621 | VB3621T | |
| VB4221 | VB4221T | |
| | | |
| | | |
| | | |
| | | |

VB's 30" High are not available in Hatteras
No shelf

2 DOORS
2 DRAWERS
1 FALSE FRONT

VANITY SINK WITH DRAWERS
30" and 34-1/2" HIGH
BUTT DOORS

Available in Randolph, Chatham, Hatteras

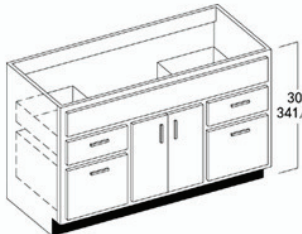
| | | |
|-----------------|---------------------|--|
| 30" HIGH | 34-1/2" HIGH |  |
| V4821D | V4821DT | |
| V6021D | V6021DT | |
| | | |
| | | |
| | | |
| | | |

Only V4821DT is available in Hatteras
No shelf

2 DOORS
4 DRAWERS
1 FALSE FRONT

VANITY DOUBLE BOWL SINK WITH DRAWERS
30" and 34-1/2" HIGH
BUTT DOORS

Available in Randolph, Chatham, Hatteras

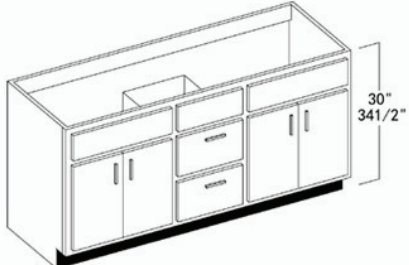
| | |
|---------------------|--|
| 30" HIGH |  |
| V6021DD | |
| 34-1/2" HIGH | |
| V6021DDT | |
| | |
| | |
| | |

Only V6021DDT is available in Hatteras
No shelf

4 DOORS
2 DRAWERS
3 FALSE FRONTS

VANITY DRAWER BASE WITH DRAWERS
30" and 34-1/2" HIGH

Available in Randolph, Chatham, Hatteras

| | | |
|-----------------|---------------------|---|
| 30" HIGH | 34-1/2" HIGH |  |
| VDB12 | VDB12T | |
| VDB15 | VDB15T | |
| VDB18 | VDB18T | |
| | VDB21T | |
| | VDB24T | |
| | | |

VDB21T not available in Hatteras

3 DRAWERS

DESK DRAWER



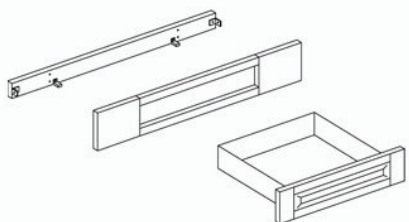





Available in Randolph, Chatham, Hatteras

| | |
|-------|---|
| DSK36 |  |
| | |
| | |

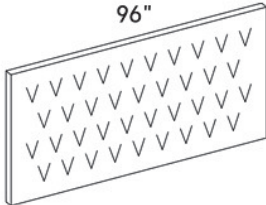

Can be cut down to 30"

VANITY

ACCESSORIES



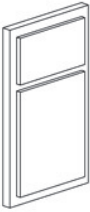

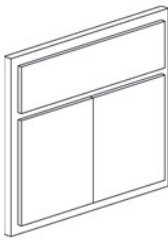
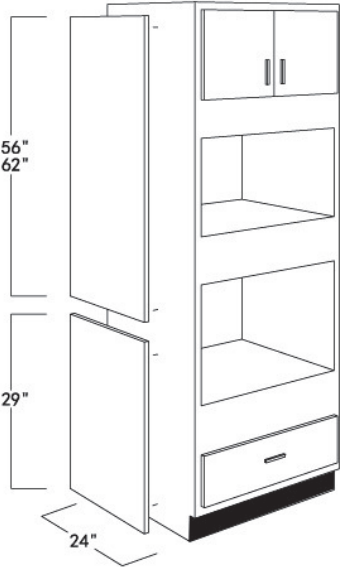
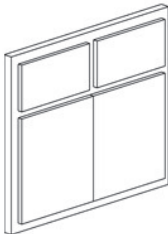
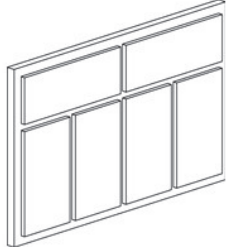

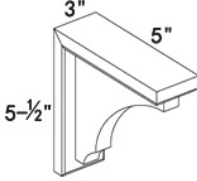

| | |
|---|--|
| <p>REFRIGERATOR END PANEL 84" & 90" HIGH 24" DEEP</p> <p>RRP84 RRP90</p>  <p>3" Wide Front Filer Stained to match Cabinets, 1/2" plywood side panel</p> <p style="text-align: right;">Available in Randolph, Chatham</p> | <p>REFRIGERATOR END PANEL 96" HIGH 24" DEEP</p> <p>RRP96</p>  <p>3" Wide Front Filer Stained to match Cabinets, 1/2" plywood side panel</p> <p style="text-align: right;">Available in Randolph, Hatteras</p> |
| <p>BACK PANELS 96" & 36" HIGH</p> <p>BP4836 BP4896</p>  <p>96" & 36"</p> <p style="text-align: right;">48"</p> <p>Stained to match Cabinets</p> <p style="text-align: right;">Available in Randolph, Chatham, Hatteras</p> | <p>DISHWASHER END PANEL 34 1/2" HIGH 24" DEEP</p> <p>DWR3</p>  <p>3" Wide Front Filer Stained to match cabinets, 1/2" plywood side panel</p> <p style="text-align: right;">Available in Randolph, Chatham, Hatteras</p> |
| <p>BACK PANELS 48" HIGH</p> <p>IBP9648</p>  <p>96"</p> <p style="text-align: right;">48"</p> <p>Stained to match Cabinets</p> <p style="text-align: right;">Available in Chatham, Hatteras</p> | <p>BASE FILLER 34 1/2" HIGH</p> <p>BF3 BF6</p>  <p>Available in Randolph, Chatham</p> |
| <p>WALL AND TALL FILLERS</p> <p>Available in Randolph, Chatham, Hatteras</p> <p>WF330 WF630 WF336 WF636 TF396 TF696</p> <p>Available in Randolph, Hatteras</p> <p>WF342 WF642</p>  <p>In hatteras only fillers 42" and 96" tall are available</p> | <p>FLUTED FILLERS</p> <p>3" & 6"</p> <p>PPCVFF330 PPCVFF336 PPCVFF342 PPCVFF630 PPCVFF636 PPCVFF642</p>  <p>30" 36" 42"</p> <p style="text-align: right;">Available in Randolph</p> |

ACCESSORIES

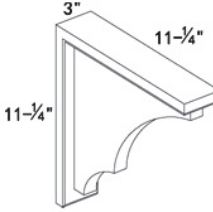
| | |
|--|---|
| <p>DECORATIVE WALL END PANEL</p> <p>Available in Randolph</p> <p>DEP1230 DEP1236 DEP1242</p>  <p>Decorative panels cut same as Doors</p> | <p>ISLAND BASE CABINET END FACE FRAME</p> <p>Available in Randolph</p> <p>BF18</p>  <p>Decorative panels cut same as doors and drawer</p> |
| <p>DECORATIVE BASE END PANEL</p> <p>Available in Randolph</p> <p>DEP2430</p>  <p>Fits on the side of Kitchen Bases Decorative panels cut same as Doors</p> | <p>ISLAND BASE CABINET END FACE FRAME</p> <p>Available in Randolph</p> <p>BF30</p>  <p>Decorative panels cut same as doors and drawer</p> |
| <p>DECORATIVE TALL END PANEL</p> <p>Available in Randolph</p> <p>DEP90 (Fits with 90" High Tall Cabinets) DEP96 (Fits with 96" High Tall Cabinets) Bottom side panel represents a BDD24</p>  | <p>ISLAND BASE CABINET END FACE FRAME</p> <p>Available in Randolph</p> <p>BF36</p>  <p>Decorative panels cut same as doors and drawer</p> |
| <p>ISLAND BASE CABINET END FACE FRAME</p> <p>Available in Randolph</p> <p>BF48</p>  <p>Decorative panels cut same as doors and drawer</p> | |

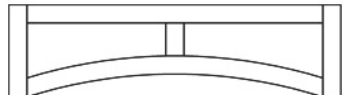
ACCESSORIES

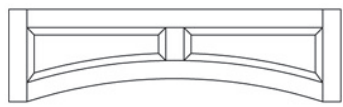
ACCESSORIES

| | |
|---|---|
| <p>SHELF SUPPORT BRACKET Available in Randolph, Chatham</p> <p>SSBV</p>  | <p>PILASTER 36" Tall Available in Randolph</p> <p>Pil 1</p>  |
| <p>SHELF SUPPORT BRACKET Available in Randolph, Chatham</p> <p>CTSB</p>  | <p>PILASTER 36" TALL Available in Randolph</p> <p>Pil 2</p>  |
| <p>VALANCE Available in Chatham</p> <p>V30FP V36FP V42FP V48FP</p>  <p>Flat Panel</p> | <p>VALANCE Available in Randolph, Chatham</p> <p>V36F V42F V48F</p>  <p>Arched Valance</p> |
| <p>VALANCE Available in Randolph</p> <p>V30RP V36RP V42RP V48RP</p>  <p>Raised Panel</p> | <p>VALANCE Available in Randolph, Chatham</p> <p>V30A V33A V36A V42A V48A</p>  |

ACCESSORIES

ACCESSORIES

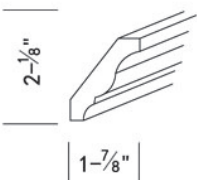
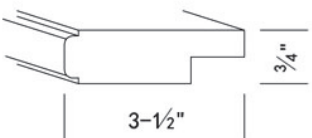
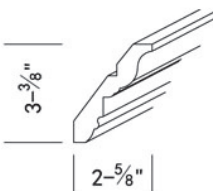
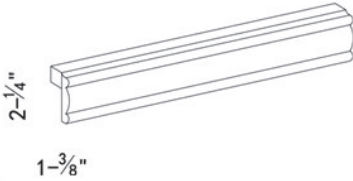
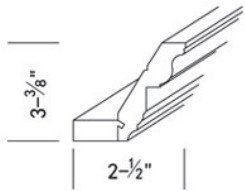
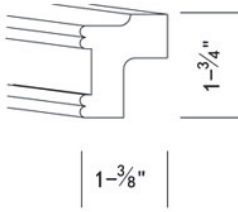
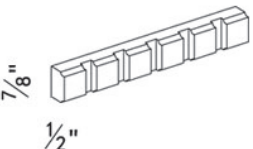
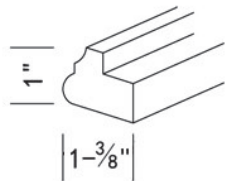
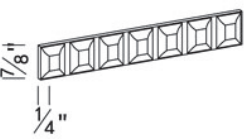
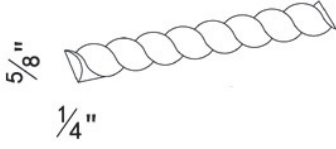
| | |
|--|---|
| <p>CROWN MOLDING 2 1/8" HIGH 1 7/8" DEEP</p> <p>CM8</p>  <p>Shipped in 8' lengths</p> | <p>MOLDING 3/4" HIGH 3 1/2" DEEP</p> <p>SBM8</p>  <p>Shipped in 8' lengths</p> |
| <p>CROWN MOLDING 3 3/8" HIGH 2 5/8" DEEP</p> <p>LCM8</p>  <p>Shipped in 8' lengths Cutout fits RM8(Rope Molding) Only</p> | <p>LIGHT RAIL MOLDING 2 1/4" HIGH 1 3/8" DEEP</p> <p>TLR8</p>  <p>Shipped in 8' lengths</p> |
| <p>CROWN MOLDING 3 3/8" HIGH 2 1/2" DEEP</p> <p>RCM4</p>  <p>Shipped in 8' lengths Cutout fits DM8, SDE8</p> | <p>LIGHT RAIL 1 3/4" HIGH 1 3/8" DEEP</p> <p>IRL8</p>  <p>Shipped in 8' lengths Cutout Fits RM8 (Rope Molding)</p> |
| <p>DENTIL MOLDING 7/8" HIGH 1/2" DEEP</p> <p>DM8</p>  <p>Shipped in 8' lengths Insert fits cutout in RCM4 Crown Molding</p> | <p>LIGHT RAIL MOLDING 1" HIGH 1 3/8" DEEP</p> <p>LRM8</p>  <p>Shipped in 8' lengths</p> |
| <p>DENTIL MOLDING 7/8" HIGH 1/4" DEEP</p> <p>SDE8</p>  <p>Shipped in 8' lengths Insert fits cutout in RCM4 Crown Molding</p> | <p>ROPE MOLDING 5/8" HIGH 1/4" DEEP</p> <p>RM8</p>  <p>Shipped in 8' lengths Insert fits cutout in LCM8 Crown Molding</p> |

ACCESSORIES

ACCESSORIES

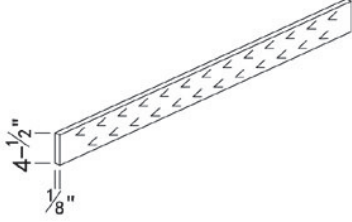
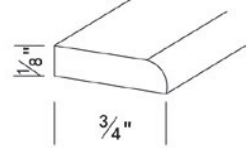
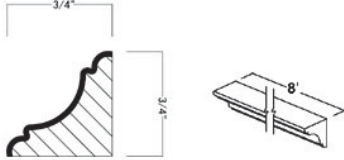
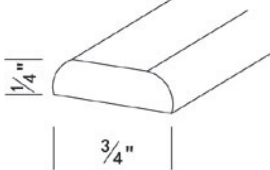
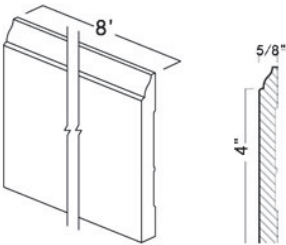
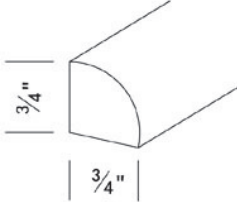
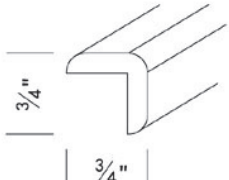
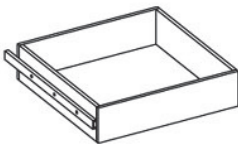
| | |
|---|--|
| <p>TOE KICK 4 1/2" HIGH 1/8" DEEP</p> <p>TK8</p>  <p>Shipped in 8' lengths</p> | <p>SCRIBE MOLDING 1/8" HIGH 3/4" DEEP</p> <p>SM8</p>  <p>Shipped in 8' lengths</p> |
| <p>INSIDE CORNER MOLDING 3/4" HIGH 3/4" DEEP</p> <p>ICM8</p>  <p>Shipped in 8' lengths</p> | <p>BATTEN MOLDING 1/4" HIGH 3/4" DEEP</p> <p>BM8</p>  <p>Shipped in 8' lengths</p> |
| <p>BASE MOLDING 4" HIGH 5/8" DEEP</p> <p>CCBB8</p>  <p>Shipped in 8' lengths</p> | <p>QUARTER ROUND MOLDING 3/4" HIGH 3/4" DEEP</p> <p>QR8</p>  <p>Shipped in 8' lengths</p> |
| <p>OUTSIDE CORNER MOLDING 3/4" HIGH 3/4" DEEP</p> <p>OCM8</p>  <p>Shipped in 8' lengths</p> | <p>ROLL OUT TRAYS</p> <p>RD15 RD18 RD21 RD24 RD27 RD30</p>  <p>Shipped in 8' lengths</p> |

BASE CABINETS & END PANELS

BASE LAZY SUSAN CABINET

Available in Hatteras

LS3612

LS3612 is sold as two parts; the cabinet ER36 and the LSkit
If you request a LS3612 both pieces will automatically
be shipped together, but they can be purchased separately.

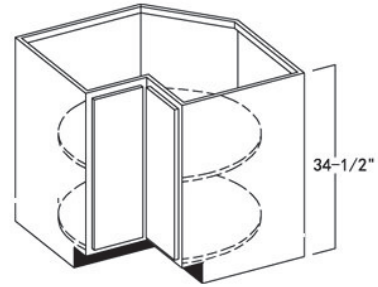

Equipped with 2 revolving shelves
Requires 36"x36" of wall space
Doors swing out and are not attached to shelves

DESK END PANEL

Available in Hatteras

DEP

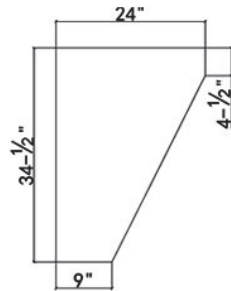

WALL DECORATIVE END PANEL

Available in Hatteras

WDEP1230
WDEP1236
WDEP1242
BDEP2430

BDEP2430 fits base sides



Decorative panels cut same as doors

TALL CABINET DECORATIVE END PANEL

Available in Hatteras

TDEP84
TDEP90
TDEP96



Decorative panels cut same as door

WALL, BASE, TALL END SKINS

Available in Hatteras

WES 11.25 x 42
BES 23.25 x 34.5
TES 23.25 x 96



Hatteras Cabinets do not come with finished sides.

WALL MULLION DOOR 30" or 36" HIGH

Available in Hatteras

- WMD2430G
- WMD3030G
- WMD3630G
- WMDCW2430G
- WMD2436G
- WMD3036G
- WMD3636G
- WMDCW2436G
- WMDCW2736G

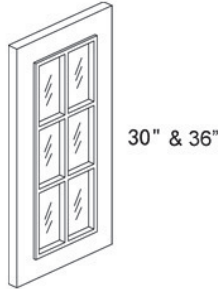

Door only, glass included
Doors for double cabinets are sold in sets

WALL MULLION DOOR 42" HIGH

Available in Hatteras

- WMD2442G
- WMD3042G
- WMD3642G
- WMDCW2442G
- WMDCW2742G

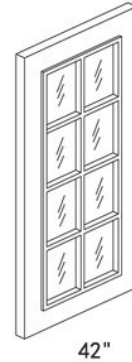

Door only, glass included
Doors for double cabinets are sold in sets

CORBELS

Available in Hatteras

- GLCOR
- GMCOR

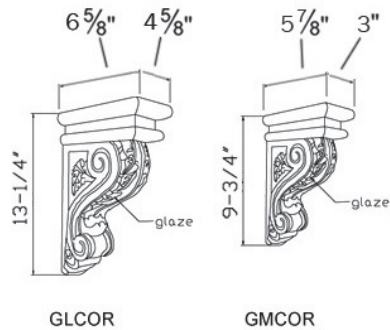

ROLL OUT TRAYS

Available in Hatteras

- RD15
- RD18
- RD21
- RD24
- RD30
- RD36



Roll Out Trays come with full extension soft close guides."

WALL END SHELVES 30" & 36" HIGH

Available in Hatteras

- WES530
- WES536

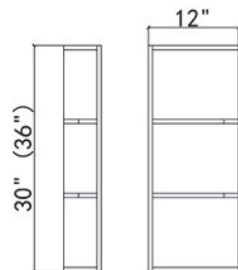

Open End shelf cabinet; 2 shelves

WALL END SHELVES 42" HIGH

Available in Hatteras

- WES542

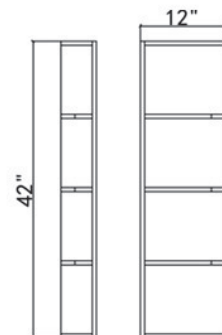

Open End shelf cabinet; 3 shelves

ACCESSORIES

VANITY BASE CABINET

Available in Hatteras

VB18



1 Door 1 Shelf 1 Drawer

WALL WINE CROSS RACK

Available in Hatteras

WWC3618
WWC3024
WWC2430
WWC2424

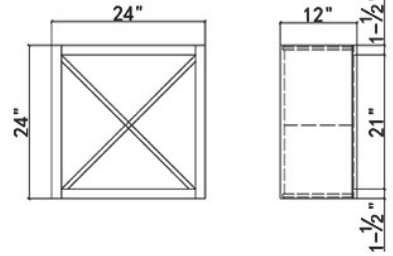

BASE FULL DOOR 6

Available in Hatteras

BFD6

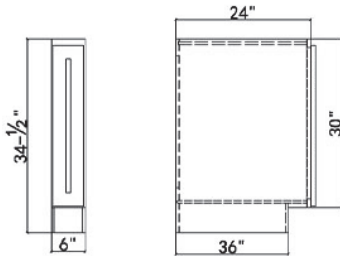

No Shelf

OVEN CABINETS

Available in Hatteras

OVEN CABINETS

OC3384
OC3390
OC3396

Oven opening is 24" w x 24" h
There are 4 1/2" Fillers on each side of the Opening
a 6" filler at the top of it.
These Can be cut down as needed to fit larger ovens.
The drawers can be cut out of the lower unit to
accommodate Double ovens.

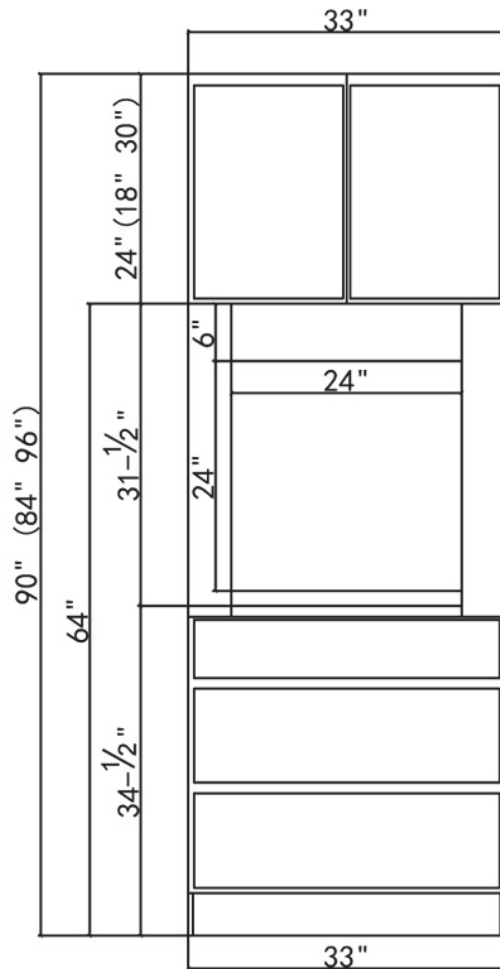

Lower Drawers may be removed to accommodate double ovens. Cabinet can be modified in the field to accept most ovens. Cabinet comes in two pieces; the lower unit is the oven cabinet and a DB33-3 (these are sold together) the oven cabinet is 33" w x 31 1/2" h the opening is 24" x 24" this can be expanded as needed the total lower unit height is 66", the upper unit is variable to work with your desired height to come out to either 84", 90", or 96" High when combined.

2 Doors 1 Oven opening, 3 Drawers

OVEN

PANTRIES (84", 90" & 96" High)

SINGLE DOOR PANTRY

84", 90" & 96" HIGH

Available in Hatteras

WP1884
WP1890
WP1896



Pantry is sold in two pieces. Lower cabinet is 54", uppers are 30", 36", 42".

4 adjustable shelves

2 DOORS

DOUBLE DOOR PANTRY

84", 90" & 96" HIGH

Available in Hatteras

WP2484
WP3084
WP2490
WP3090
WP2496
WP3096

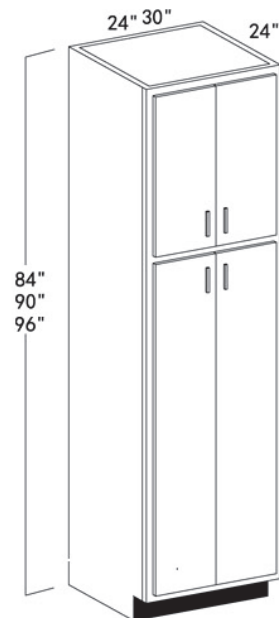

Pantry is sold in two pieces. Lower cabinet is 54", uppers are 30", 36", 42"

4 Adjustable shelves

4 DOORS

ACCESSORIES

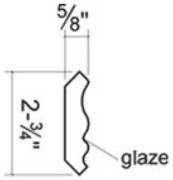
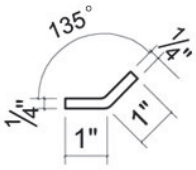
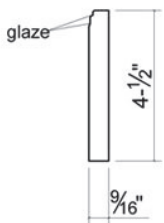
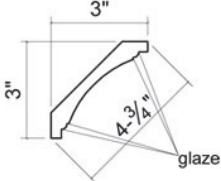
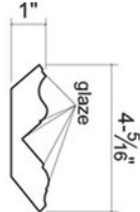
| | |
|---|---|
| <p>CROWN MOLDING 2 3/4" HIGH 5/8" DEEP</p> <p>Available in Hatteras</p> <p>CM8</p>  <p>Shipped in 8' lengths</p> | <p>OUTSIDE CORNER MOLDING 135 Available in Hatteras</p> <p>135° OCS</p>  <p>Shipped in 8' lengths</p> |
| <p>FURNITURE BASE MOLDING Available in Hatteras</p> <p>4 1/2" HIGH 9/16" DEEP</p> <p>Furniture base(FB8)</p>  <p>Shipped in 8' lengths</p> | <p>FURNITURE CROWN MOLDING Available in Hatteras</p> <p>3" HIGH 3" DEEP</p> <p>FCR8</p>  <p>Shipped in 8' lengths</p> |
| <p>CROWN MOLDING Available in Hatteras</p> <p>4 5/16" HIGH 1" DEEP</p> <p>LCM8</p>  <p>Shipped in 8' lengths Cutout fits RM8 (Rope Molding) Only</p> | |
| | |
| | |

ACCESSORIES